



**Giovanetti**

# le nuvole

*L'anticonformismo di uno "spirito libero" del design italiano, un progetto che si ispira ironicamente alle linee degli anni '50, e le rivisita senza togliere l'attenzione al confort.*

*A "free spirit" of italian design, a project which is inspired by the lines of the 50ies, with irony, without distracing actentio from the comfort.*

Sergio Giobbi, 2010



**Giovanetti**







# le nuvole

Struttura e spalliera in legno multistrati e acciaio. Imbottitura seduta e spalliera in poliuretano a densità differenziate, protette con tessuto e fibre sintetiche per un miglior confort. Piedi in PVC.

Seat and backrest with wooden structure in multilayers and steel. Seat and backrest padding in polyurethane foam of different layers covered with tissue and synthetic fibers for better confort. Feet in PVC.

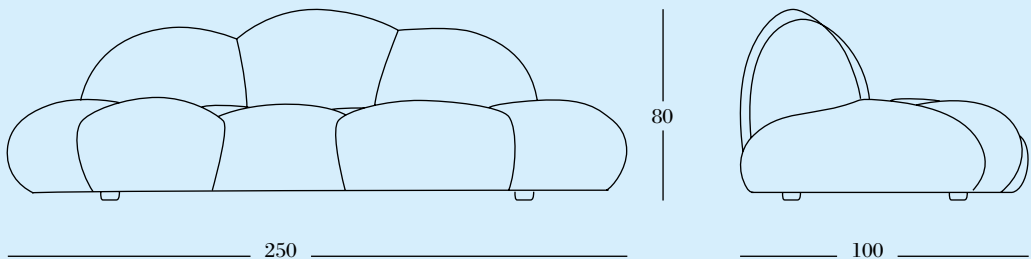



**Giovanetti**



# papillon

*Il grande fascino del gruppo conversazione  
pensato e progettato per far sognare, piccoli  
e grandi, in una seduta estremamente  
confortevole.*

*The Papillon series... Designed and  
conceived to steal your heart away. Comfort  
and elegance for an informal life – style.*

G. Rosati, 1972









# papillon

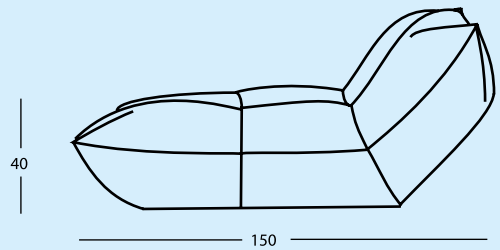
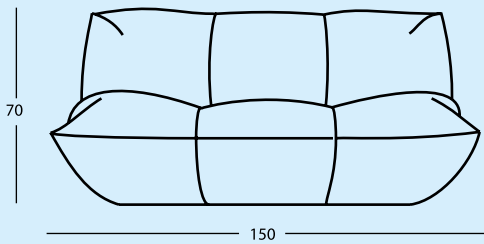
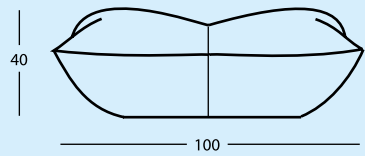
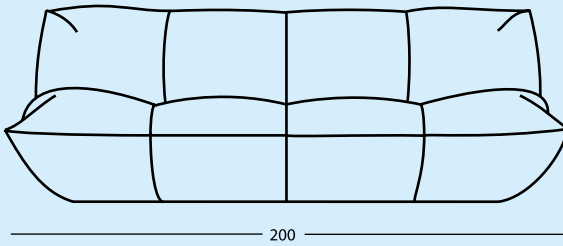
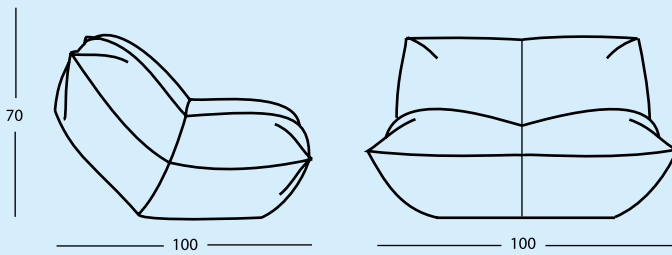



**Giovanetti**





# jetson

*Jetsons identifica un modo di sedersi contemporaneo, informale e più libero. Jetsons è un'amaca, una chaise-longue, un trono tribale, un sedile di un'astronave, una culla, un nido, con la sua forma morbida, accogliente, e allo stesso tempo dinamica, moderna, sensuale e aliena.*

*The Jetsons defines a contemporary way of sitting: free and informal. Jetsons is a hammock, a chaise-longue, a cradle, the seat of a space-ship, a tribal throne, a nest, comfortable, and at the same time dynamic, up - to - date, sensual and alien.*

G. Berchicci, 2001



# jetson

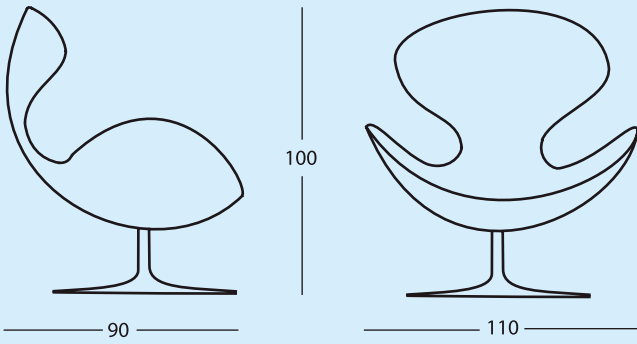

**Giovanetti**



**Giovannetti**





flower



# flower

Struttura portante in profilato d'acciaio, base d'acciaio taglio ovale laser. Verniciata a polvere colore argento, imbottitura poliuretano ad alta densità protetta ed ovattata con tessuto e fibra, per un comfort assoluto. La sua realizzazione è a forma di fiore.

“Inox” steel frame. Oval-shaped steel base, white, black or silver painted. The padding is made of shaperetaining polyurethane covered with protective fabric. The covering available are: multicolour fabric, leather, or coated ...

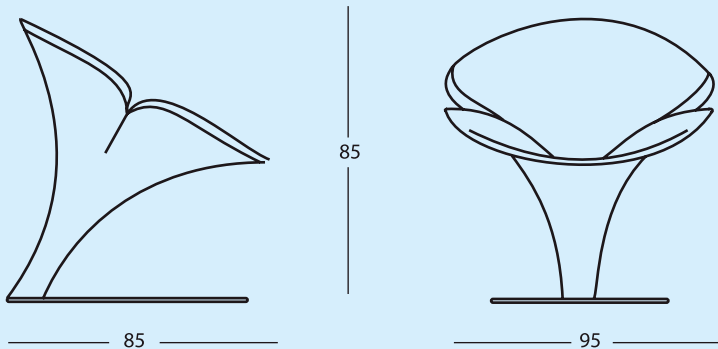



**Giovanetti**





# anfibio

*Anfibio nasce nel 1970  
da un'idea rivoluzionaria.  
Definito dalla critica di tutto  
il mondo, il divano opera d'arte.  
Realizzato oggi con materiali  
estremamente adatti alle  
molteplici funzioni che offre.  
Qualità e artigianalità lo hanno  
reso unico nel suo genere.*

*Although Anfibio's unique timeless style  
has remained constant over the years,  
this cult classic has been continually  
updated with innovations, making it ever  
more multi – use functional.*

Project: Alessandro Becchi, 1970









# anfibio

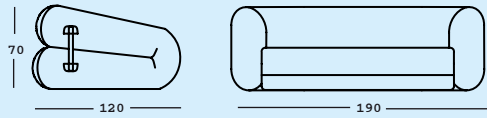

anfibio 190

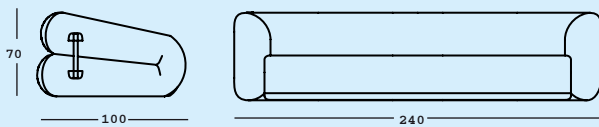
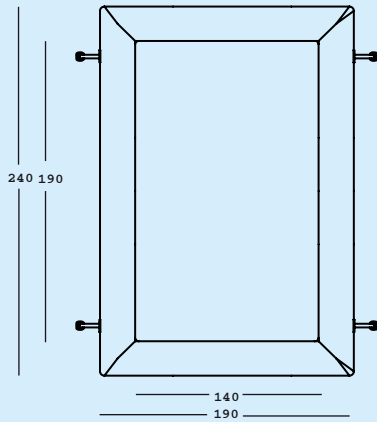

anfibio 240

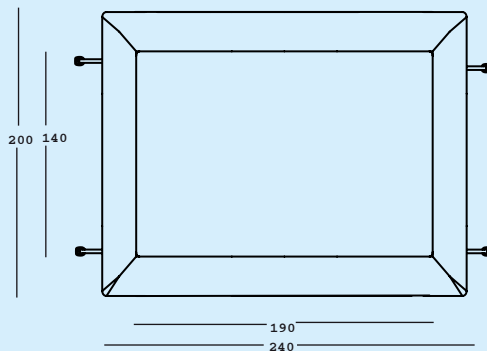





**Giovanetti**

# anfibio

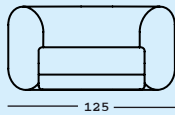
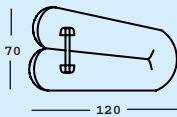

## anfibio poltrona

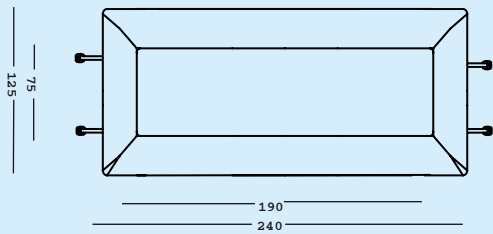



**Giovanetti**





**Giovanetti**





# gabbiano

*La combinazione dei suoi materiali,  
unita alla sensualità e dolcezza del  
suo movimento, donano a gabbiano il  
fascino di un'isola per il relax.  
Gabbiano è dotato di cilindretti che  
consentono di bloccare la posizione  
della seduta.*

*The mix of its materials, combined  
with the sensuality and charm of  
its movement, gives Gabbiano the  
fascination of a relaxing island.*

project: C. Silva gil, 2003



**Giovanetti**





# gabbiano

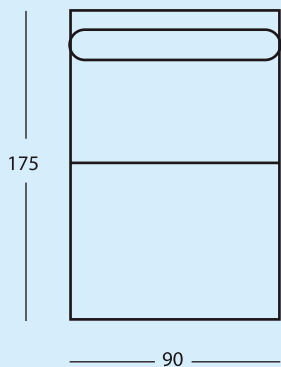
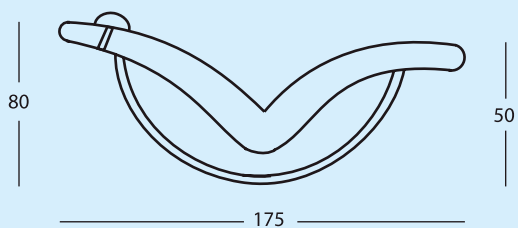



**Giovannetti**







# ancella

*Una piccola poltroncina di servizio - comoda,  
divertente e pratica - per la camera o lo spogliatoio.*

*Struttura in legno. Imbottitura in poliuretano  
indeformabile rivestito con tessuto protettivo.*

*Schienale: appendiabito in faggio nei colori  
naturale, tinto noce o ciliegio.*

*Rivestimento sfoderabile.*

*Nella seduta esiste un contenitore,  
per riporre tutto ciò che  
non vogliamo mettere in evidenza.*

*A small bedroom chair, functional and elegant  
at the same time. Frame in wood. Upholstery in  
indeformable polyurethan covered with dacron and  
protective tissue. Backrest: cloth hanger in natural  
beechwood Seat: tip-up seat with container. Feet:  
Natural beechwood Cover: completely removable*

project: Mauro Lovi, 1994



**Giovanetti**



**Giovannetti**



**Giovannetti**

# ancella

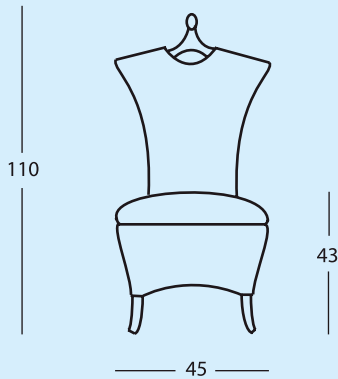
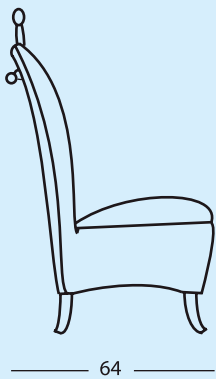



**Giovanetti**



# le sorelle di ancella

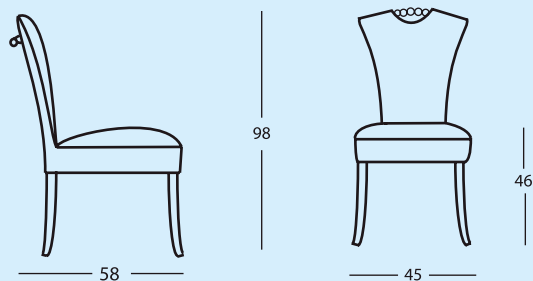

## luigia

*Fin da bambina con la Sua collana portava ovunque un senso di eleganza e sobrietà. I moderni particolari sartoriali, permettono a Luigia di essere completamente sfoderabile con semplicità.*

*Notice Luigia's lovely necklace...and how her elegant covering is designed to be easily and quickly removed. Are you intrigued?*

project: Mauro Lovi, 1994

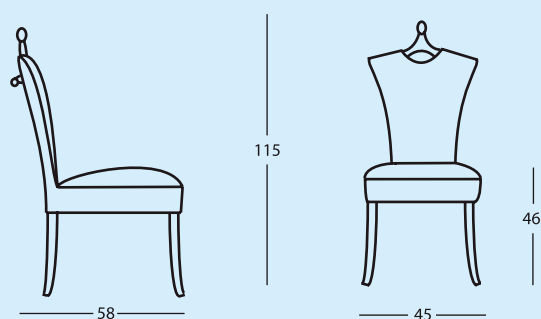

## mirandolina

*Oltre ad avere una comoda seduta, offre nella casa ed in albergo una serie di servizi utili per mettere ordine sia in camera che nello spogliatoio.*

*Other than being very comfortable, Mirandolina is a perfect bedroom chair, suitable for the home and the hotel.*

project: Mauro Lovi, 1994



**Giovanetti**



# roly poly

*Un gioco per bambino di ogni età, ispirato al  
balocco, molto popolare negli anni '50.*

*For the child in all of us, inspired by the  
Roly-Poly toy, popular during the 1950's*

project: G. Rosati, 2000



# roly poly

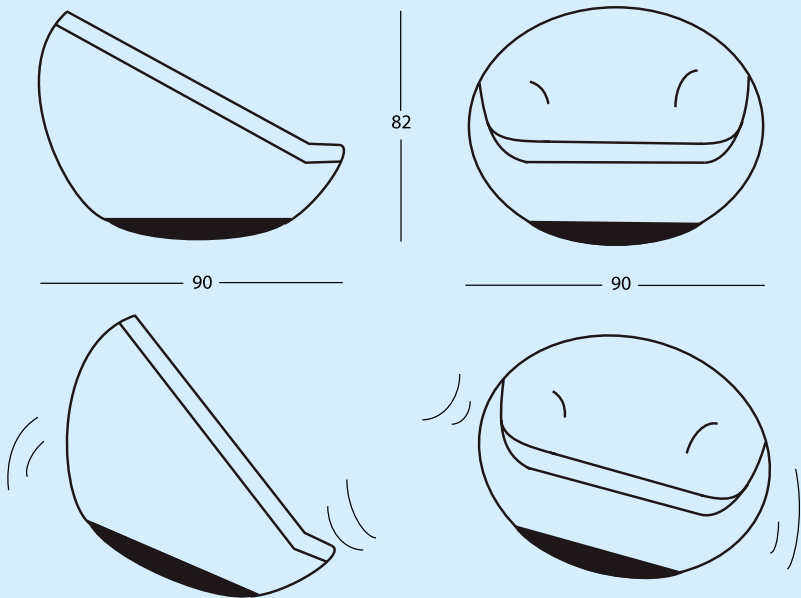

**Giovanetti**



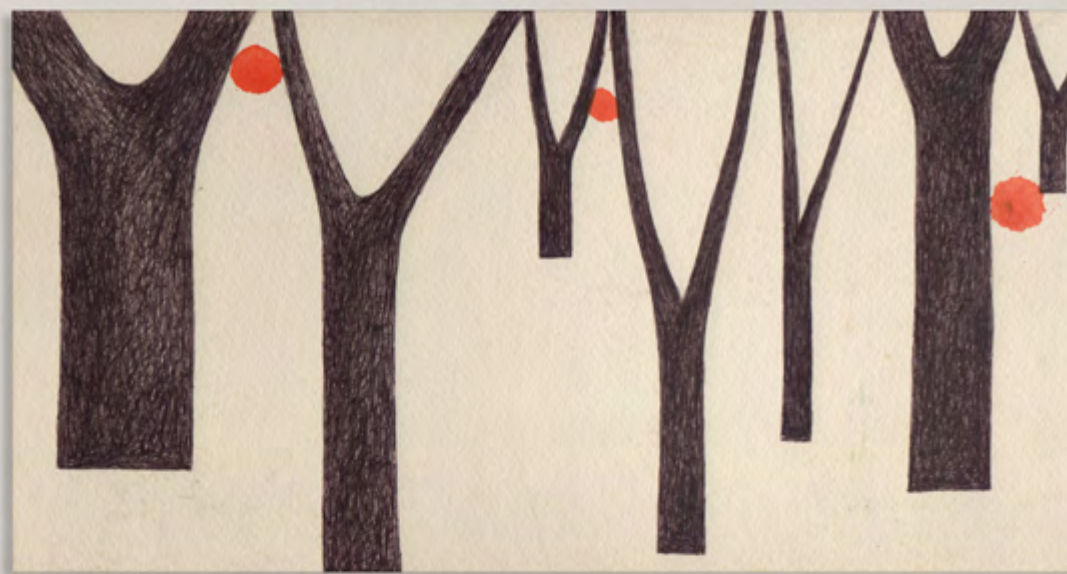





# galassia

*Sistema composto da quindici elementi di diverse dimensioni, liberamente aggregabili tra loro, rotondi, rettilinei, angolari, simmetrici, asimmetrici, sedute lunghe-relax, componibili, unici.*

*Modular system composed of 15 forms: round, rectilinear, angular, symmetrical, asymmetrical, etc... All freely combining with each other.*

project: S. Giobbi, 2001













**Giovannetti**



**Giovanetti**



# galassia

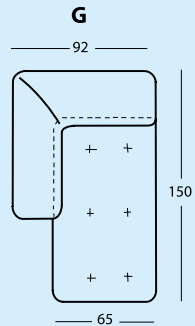
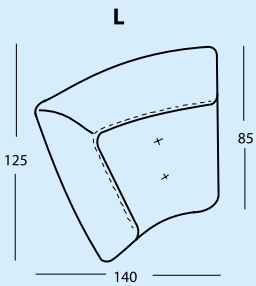
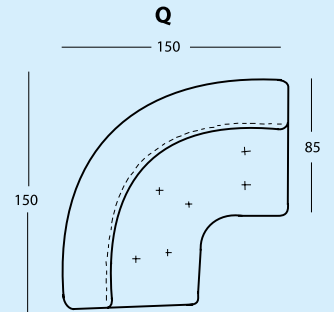
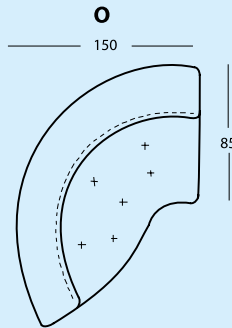
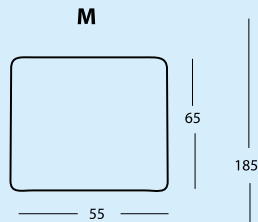
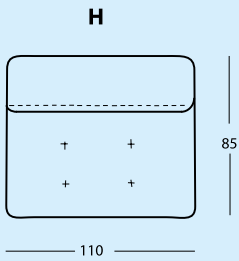
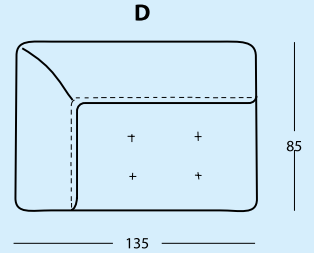
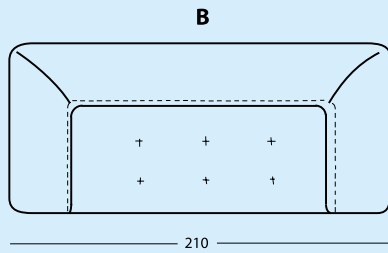
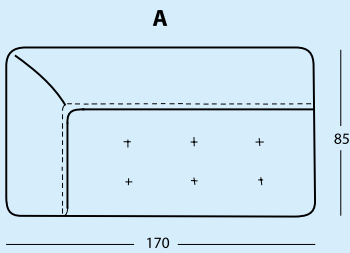
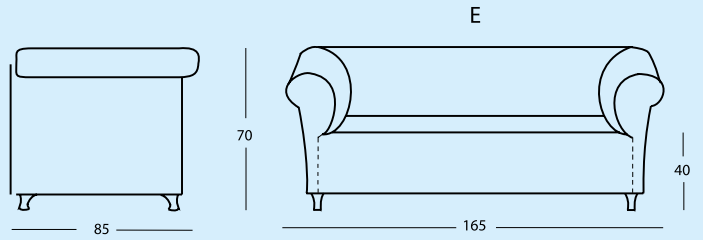



**Giovannetti**



# bubba

*Un sistema di sedute di grande componibilità,  
composizioni dritte e curve, strutture in  
lamellare di multistrati con cinghie  
elastiche rinforzate, per un ottimo molleggio.  
Bracciolo imbottito ed in acciaio  
spazzolato, finitura satinata.*

*An unusual kind of sectional seating with a  
sinuous metallic or upholstered armrest. Bubba's  
various sections may also be used singularly.*

project: n. delfinetti, a. scarpitta, 2001







**Giovannetti**



**Giovannetti**



# bubba

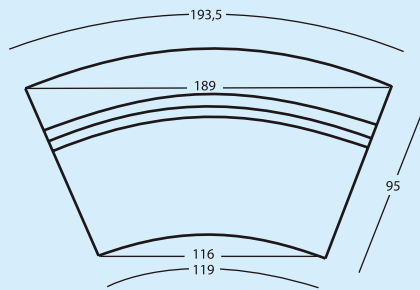
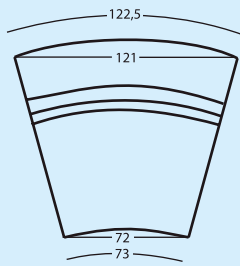
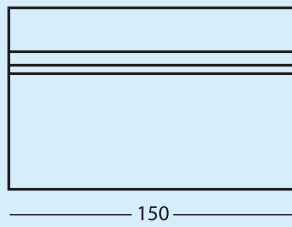
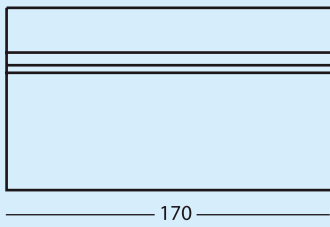
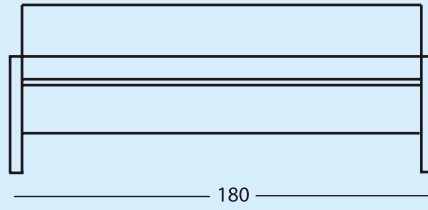
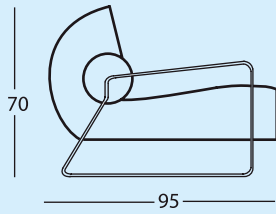



**Giovanetti**





# i girovaghi

*Un sistema di sedute che arricchisce ed innova  
il paesaggio domestico. Un invito alla  
convivialità informale e stravagante.*

*A system of sectional seating that enriches  
and renews the domestic landscape. An  
invitation to an informal, eccentric and  
convivial way of living.*

project: R. M. Banci, 1996



# i girovaghi

Elemento A

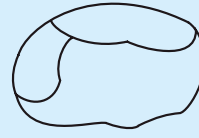
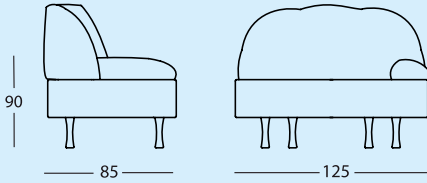

**A** sx

125 x 85 x h 90

Elemento B

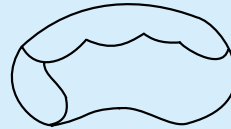
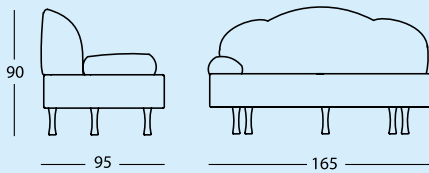

**B** sx

165 x 95 x 90

Elemento C

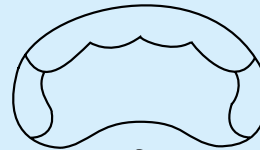
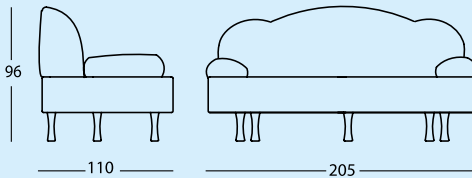

**C**

205 x 110 x 96

Elemento D

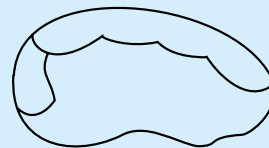
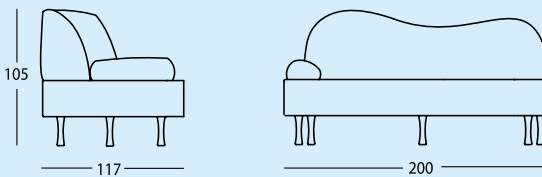

**D** sx

200 x 117 x h 105

Elemento E

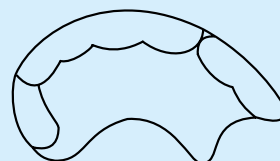
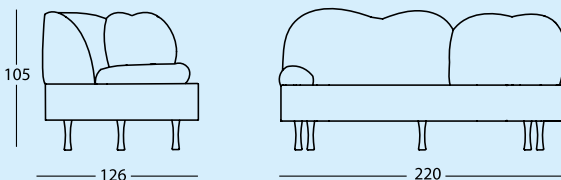

**E** sx

220 x 126 x h 105



**Giovannetti**





# love

*Struttura: lana di vetro rinforzata con profili d'acciaio. Base in acciaio inox satinato e spazzolato, oppure verniciato nei colori della scocca. Imbottitura in poliuretano indeformabile ad alta densità, rivestito con tessuto protettivo. Seduta girevole. Scocca di serie nei colori: argento metallizzato, bianco e rosso lucido.*

*Body frame: fibre glass reinforced with steel profiles. Basis in satin and brushed inox steel, or stained in the same colours as the body is. Padding in high density shape-retaining polyurethane foam covered with protective fibre. Swivel seat. Body in series is: silver metal, shiny red or white.*

project: Sandro Santantonio





**Gioiannetti**



**Gioannetti**

love

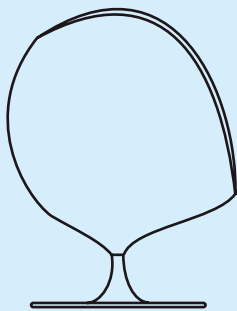

82

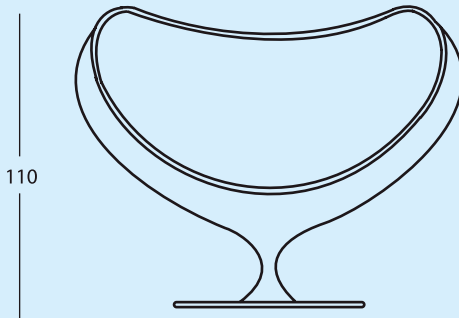

135

110

**Giovanetti**



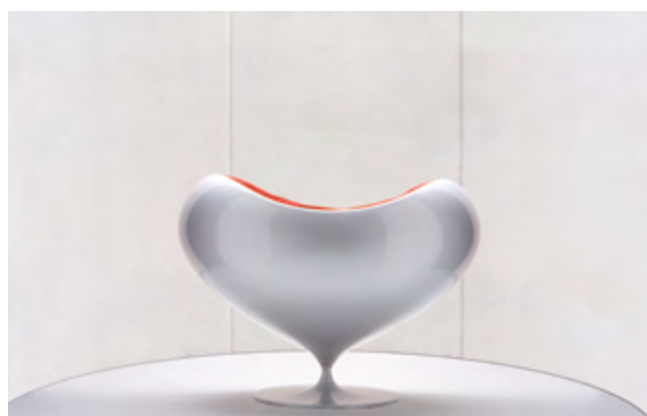



# anemone

*Muoversi come pesci felici in un caldo mare  
di forme, sentirsi protetti perchè accolti  
all'interno di un coloratissimo anemone.*

*Swiming like happy fishes in the warm shapes  
of sea, feeling comfortable and protected  
within the big embrace of a colourful  
anemone.*

Project: Giancarlo Zema, 2011

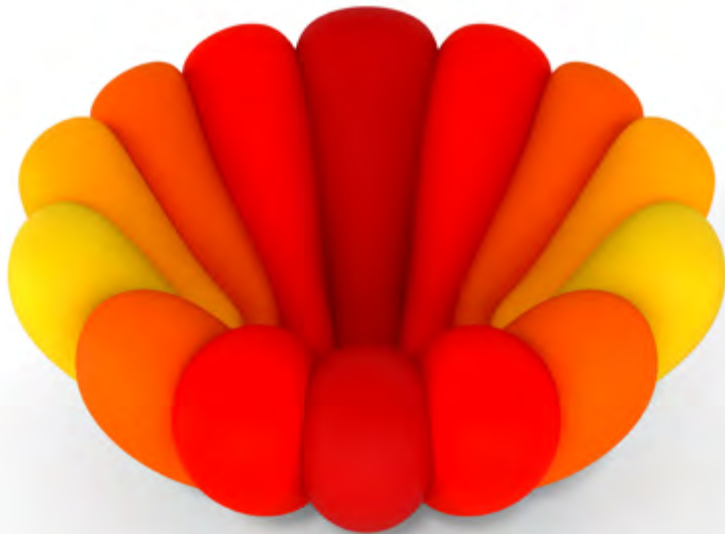

**Giovannetti**

# flower

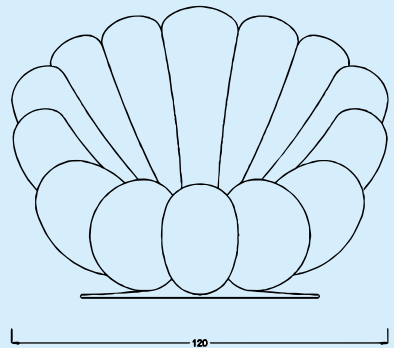
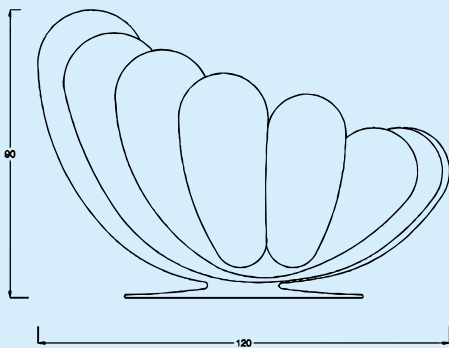







**Gio Piretti**



**Gioiannetti**



# foyer

*Linee morbide semplici ed eleganti per un divano che diviene assolutamente innovativo nella sua versione Strip, che grazie ad una zip lungo tutto il perimetro si sfodera e si riveste con facilità. Anche con doppio rivestimento reversibile!*

Sergio Giobbi, 2011



**Giovanetti**





**Giovanetti**





**Giovannetti**

# foyer

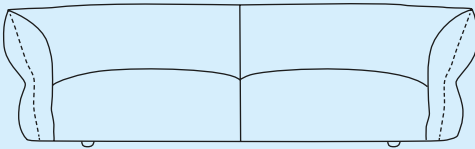
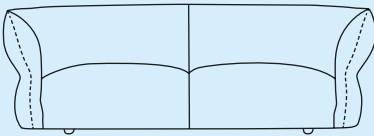
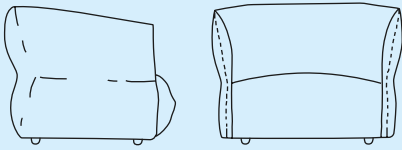



**Giovannetti**



**Giovannetti**



**Giovannetti**





# boss

*Destinato ad un pubblico che ama circondarsi di oggetti caratterizzanti e dalla forte personalità. Passati gli anni freddi del minimalismo, la giovannetti ha voluto riscoprire le linee sinuose, la straordinaria comodità, la forza e la decisione del disegno di questo prodotto che negli anni '80 già aveva ottenuto uno straordinario successo anche cinematografico.*

*Boss is directed to a public who loves "objects" with distinguishing character and a strong personality. After years of rigorous minimalism, giovannetti brings back the forceful sinuous lines and extraordinary comfort of a design that has even achieved fame in films and television.*

Paolo Piva, 1979



**Giovannetti**

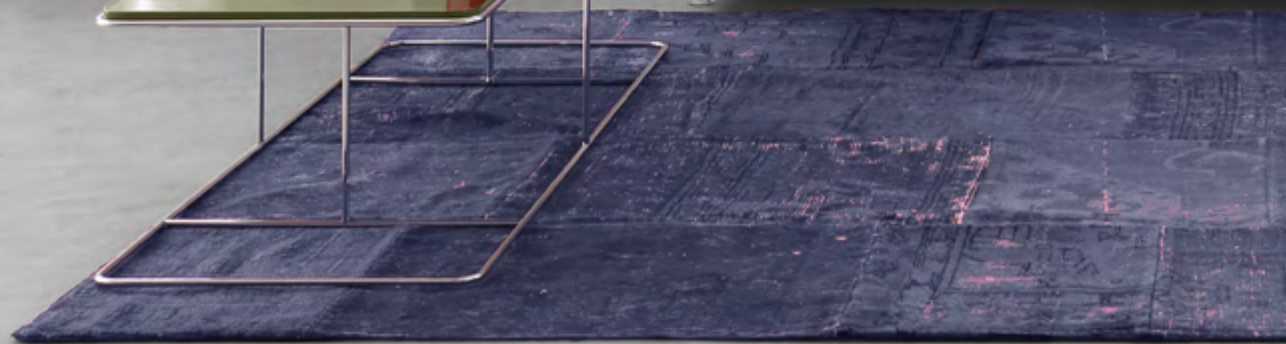





boss

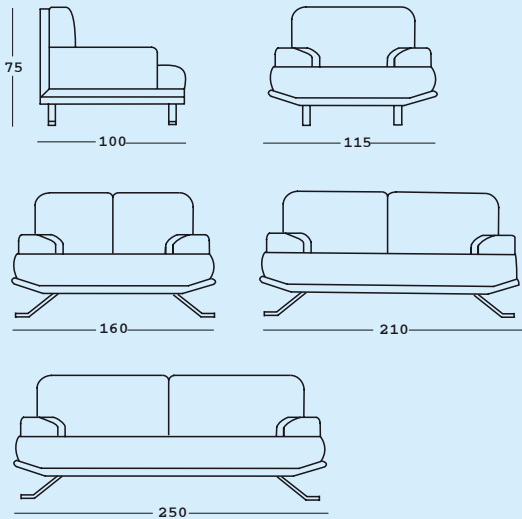

Piedino Affeta

Giovannetti





**Giovannetti**

# boss

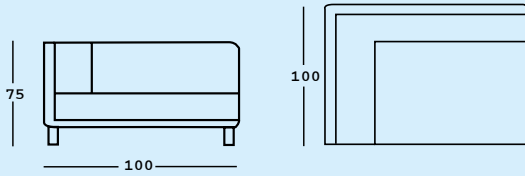

Piedino Boss B

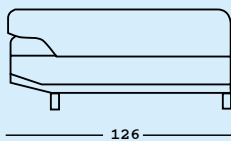
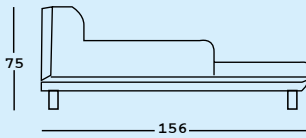
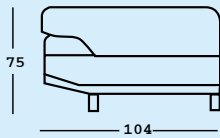
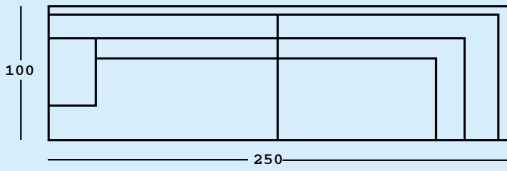
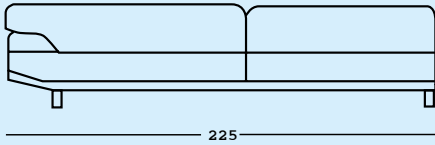
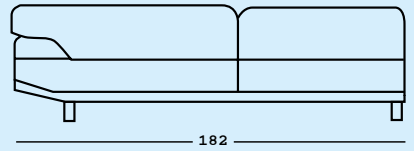
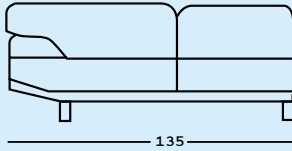
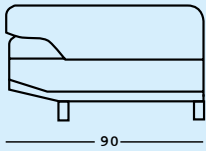



**Giovannetti**



# battigia

*Morbido, confortevole, ma soprattutto adatto ai piccoli spazi oppure a soluzioni decorative.*

*Soft, comfortable, especially suitable for small rooms...or as a decorative accent.*

Project: Atelier Associati, 1998



**Giovannetti**



# battigia

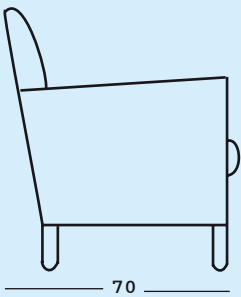

85

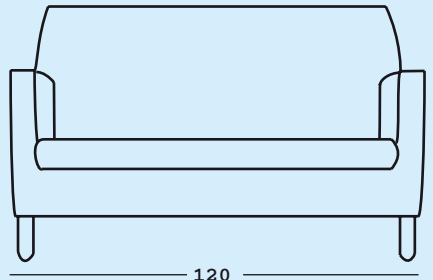
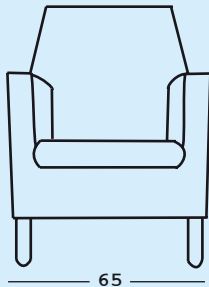

**Giovannetti**





# giramondo

*Seduta centrale. Le linee essenziali di questo elemento a tutto tondo lo rendono facilmente inseribile in qualsiasi contesto, oppure può inserirsi come oggetto "unico" per spazi quali alberghi, negozi, sale d'attesa...*

*A delightful sculpture piece that reveals itself as functional and comfortable seating. Perfect for hotels, shops, waiting rooms... wherever people gather.*

Project: N. Delfinetti, 2002



# giramondo

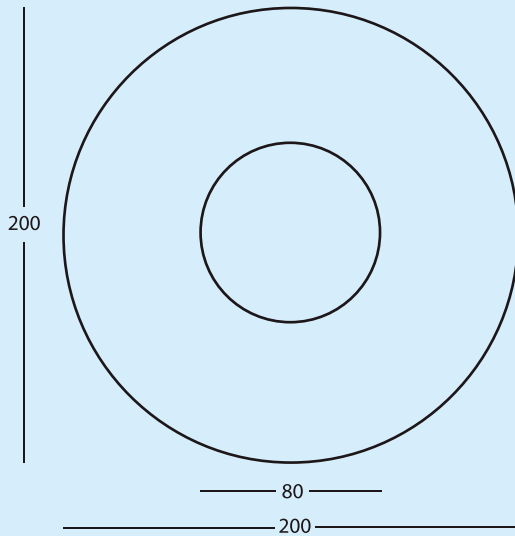
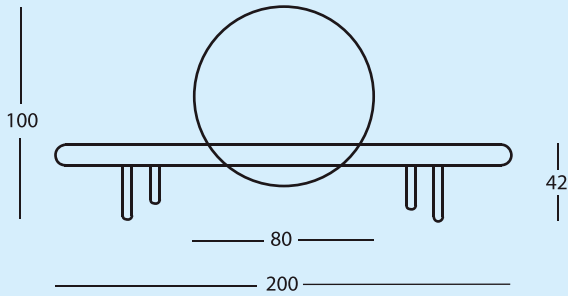





**Giovannetti**



# circus

Un disegno che ricorda una buccia d'arancia, ma anche una conchiglia, o il movimento del vento. Noi abbiamo preferito associarlo al movimento circolare di una girandola, o a quella arena circolare dove si svolge lo spettacolo, quello della vita di ogni giorno. Una poltrona relax, ma anche un divanetto "vis a vis".



**Giovannetti**

# circus

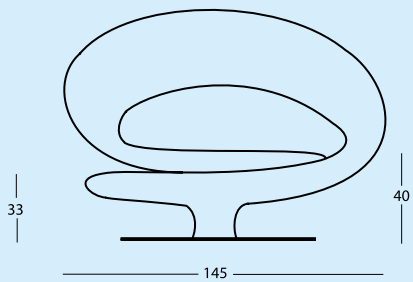
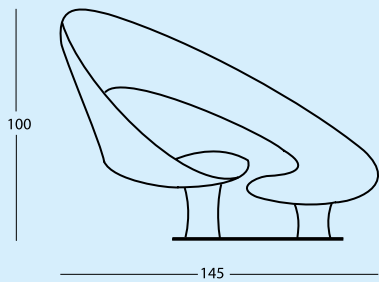







# carlton

*Carlton si rivolge a tutti coloro che vivono in modo naturale e rilassato e desiderano vivere in un ambiente confortevole per ricevere e conversare. Carlton afferma il suo comfort estremo attraverso forme arrotondate e morbide che creano uno spazio conviviale, rendendolo unico nel suo genere.*

*With its generous comfort underlined by its soft, rounded shape, Carlton will appeal most to lovers of an informal, relaxed lifestyle, who want to welcome their friends in the most convivial way possible. Not forgetting, of course, that Carlton does not look like any other seat in existence*









# carlton

Carlton è disponibile nelle versioni poltrona singola, e divano a due e tre posti. Imbottiti con struttura in legno e rinforzi metallici, imbottitura in schiume poliuretaniche a densità differenziata. Rivestimento sfoderabile in velluto, tessuto o pelle. Gambe in metallo cromato. Tavolino con struttura rivestita in pelle e gambe in metallo cromato.

*Carlton is available as armchair, two-seater and three-seater sofa. Upholstered elements with wooden structure and metal inserts, goose feather and different densities polyurethane foams padding. Velvet, fabric or leather removable cover. Metal chromed feet. Low table with leather top and metal chromed structure.*

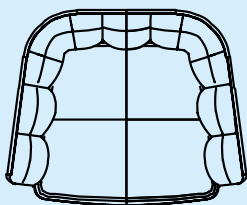
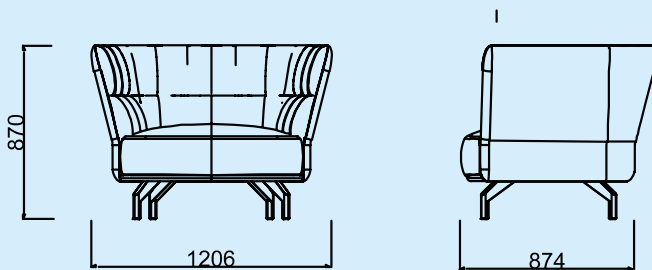
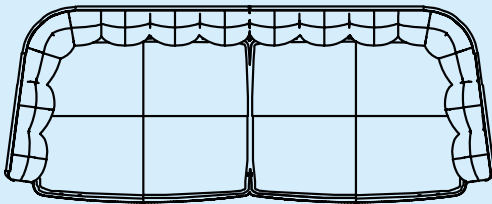
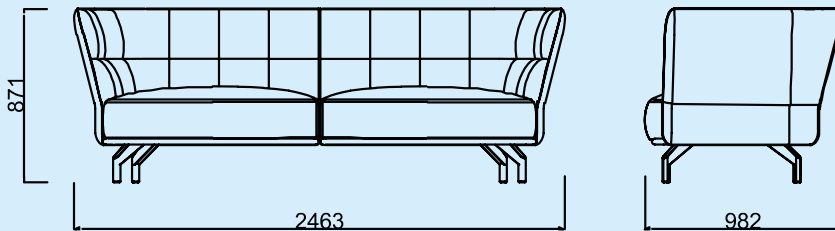





**Giovannetti**



**Giovanetti**



**Giovannetti**

# carlton

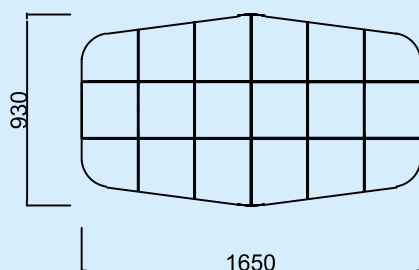
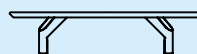
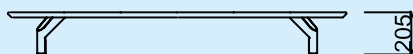
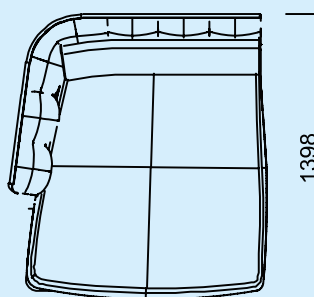
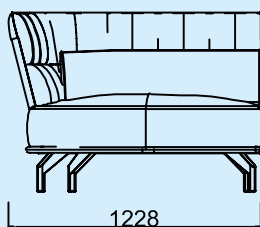
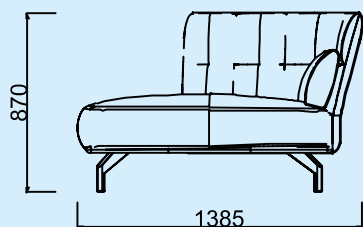



**Giovannetti**





# bolle

*Sempre legata al gioco e a quel “sapore morbido” della vita, la nuova poltrona di Giovannetti, progettata da Sergio Giobbi.*

*Realizzata in poliuretano schiumato con struttura metallica interna. Base d'appoggio a terra; distanziali in PVC.*

*As usually linked to the game and “that kind of soft flavour” of life, the new chair of Giovannetti, designed by Sergio Giobbi.*

*Produced in polyurethane foam with internal metal structure. Wooden base with PVC feet.*

project: Sergio Giobbi, 2008



**Giovannetti**

# bolle

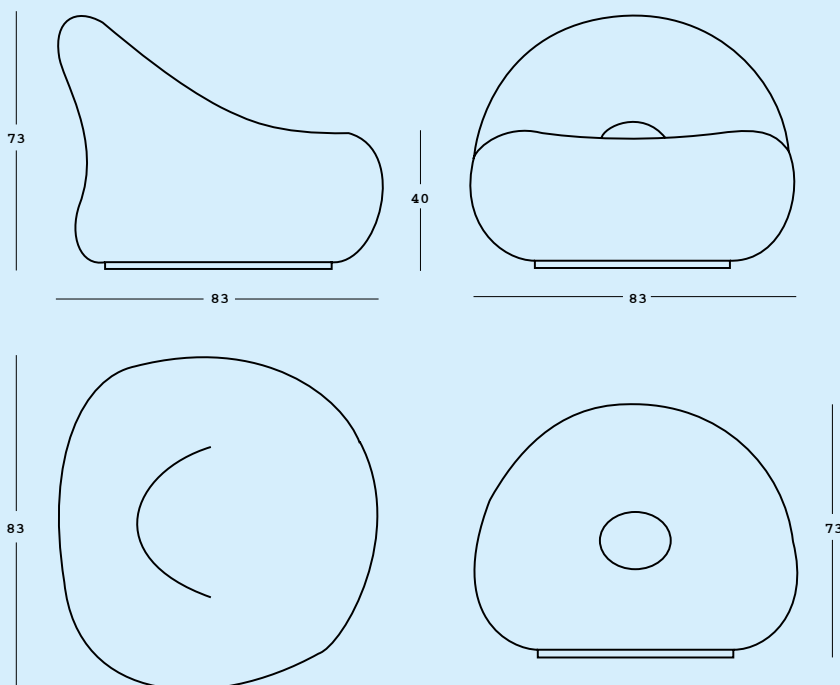

**Giovannetti**







# gongolo

*La calda sensazione rassicurante dell'essere cullato in una forma rotondeggiante e ben equilibrata nei pieni e nei vuoti, un'oggetto familiare che ripropone un'antica consuetudine.*

*The warm sensation of being rocked in the cosiest armchair. A homey object linked to an ancient tradition.*

project: Atelier Associati, 1995



**Giovannetti**

# gongolo

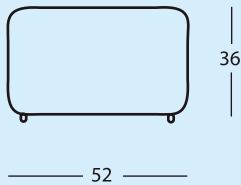
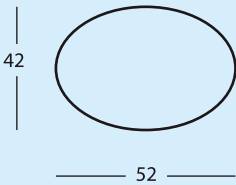
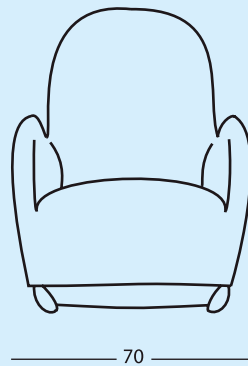
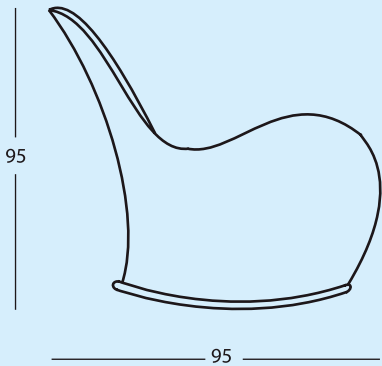



**Giovanetti**



# momma

*Poltrona proposta in tre misure XS,  
M, XL come le magliette T-shirt.  
Sedute giovani, pratiche ed eleganti  
che accompagnano affettuosamente la  
crescita dall'infante all'adulto.*

*An armchair offered in three sizes, XS,  
M, XL, just like your favorite T-shirt.  
Youthful, practical and elegant, they're  
suitable for the entire family.*

project: M. Pallecchi, 1995





# momma

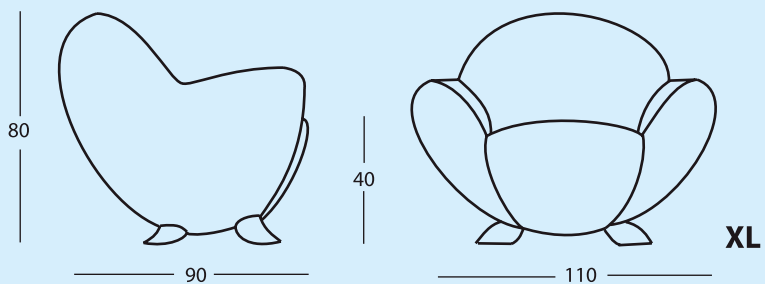
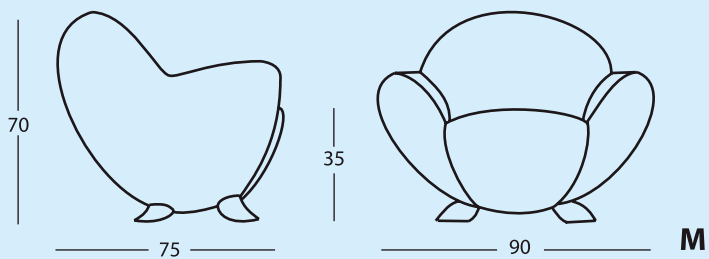
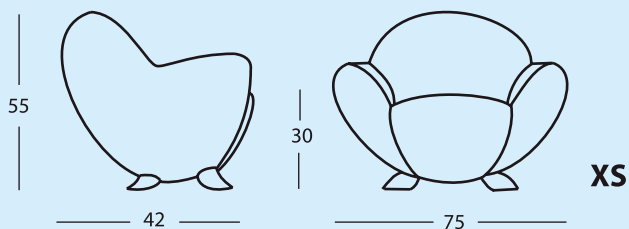



**Giovanetti**



# daisy

*Daisy, una sedia con la base a forma di slittino, tutte comode e confortevoli.  
Struttura della seduta in Abs Base in acciaio  
Imbottitura in poliuretano indeformabile  
rivestito con tessuto protettivo Rivestimento in  
pelle, tessuto, spalmato...*

*Designed in the form of delicate flower petals, Daisy is wellcoming and comfortable.  
Seat frame in "abs". "Inox" steel base.  
The padding is made of shaperetaining polyurethane covered with protective fabric.  
The covering available are: multicolour fabric, leather, or coated...*

project: sandro santantonio, 2005



**Giovannetti**

# daisy

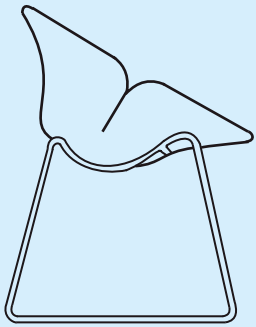

63

75

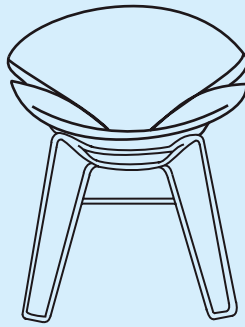

63





**Giovanetti**



# star sistem











# star

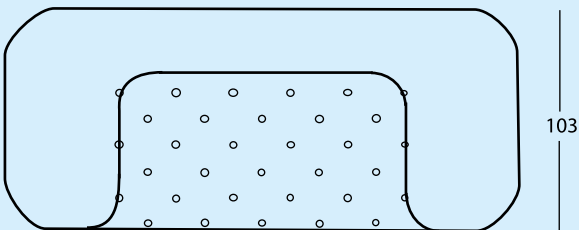
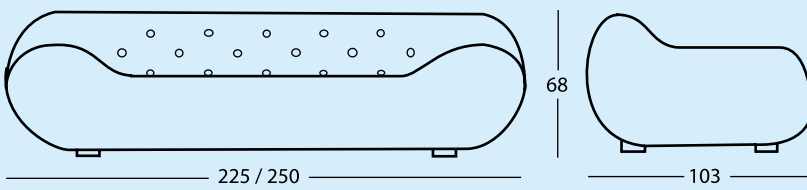



**Giovannetti**





# superstar

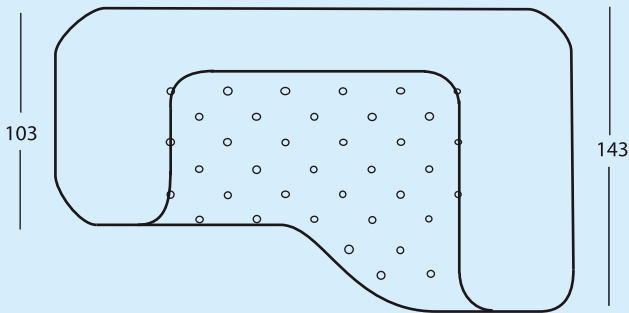
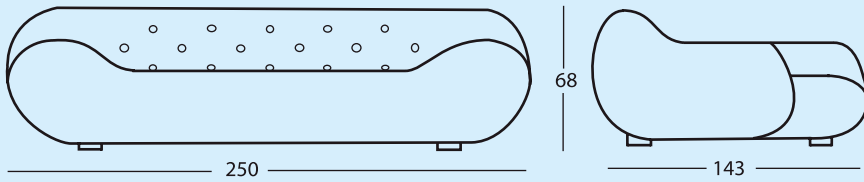





**Giovannetti**





# starlounge

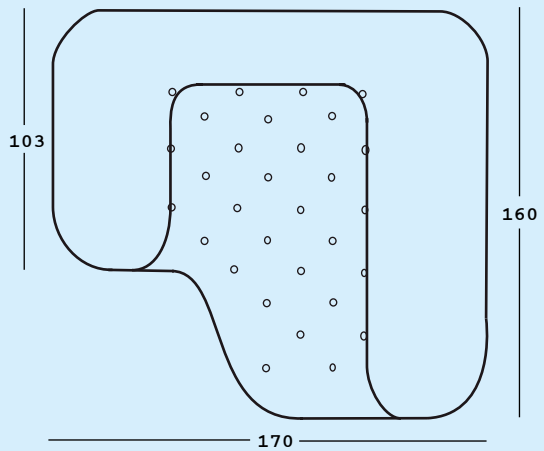
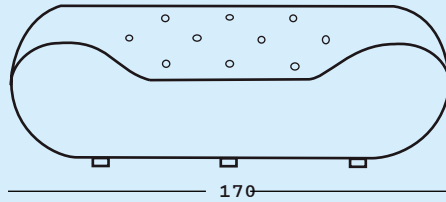
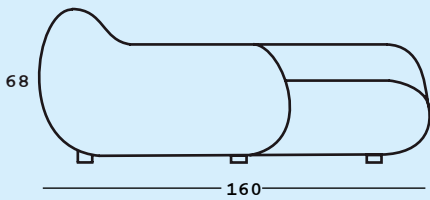



**Giovannetti**





re sole



**Giovanetti**











**Giovanetti**





**Giovannetti**





# re sole

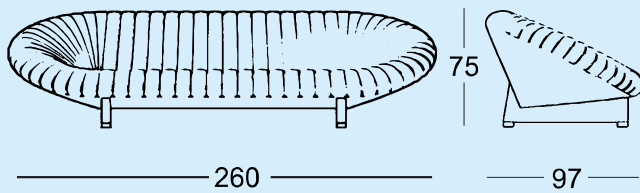
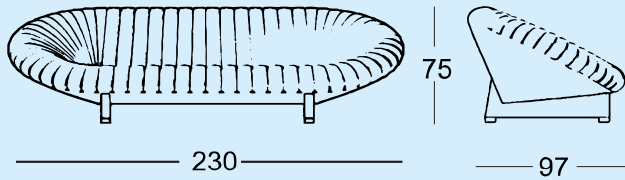





**Giovanetti**





# l'agostina

*Un modello dalle linee tonde e spiritose, pensato per la casa giovane e disinvolta.*

*A spirited piece with rounded lines, expressly designed for the home that's young and lively.*

project: Barbero & Navone, 1994



**Giovannetti**

# l'agostina

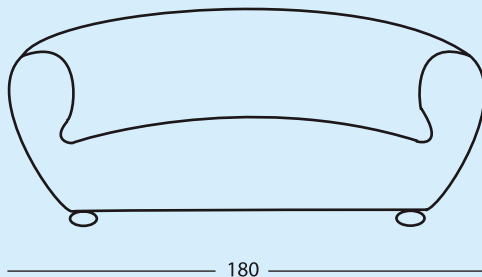
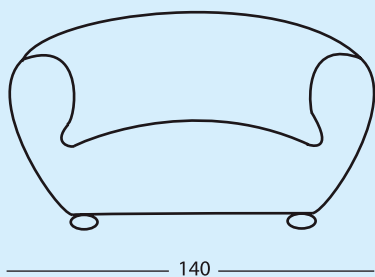
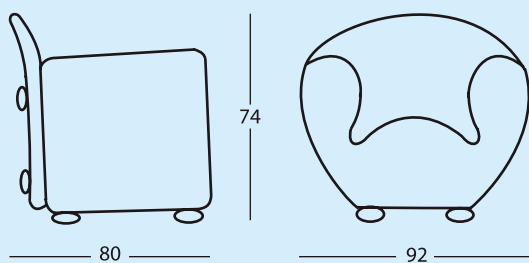



**Giovanetti**





# circe

*Una poltrona-relax pratica, elegante e confortevole, per il piacere di godersi il proprio tempo libero.*

*Practical, elegant and comfortable... a chaise-longue designed for beauty and relaxing pleasure*

Project: Atelier Associati, 1993



**Giovanetti**

# circe

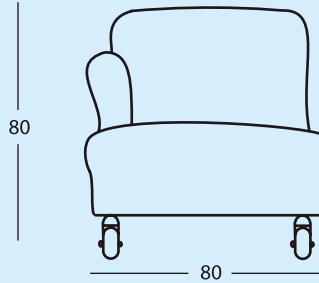
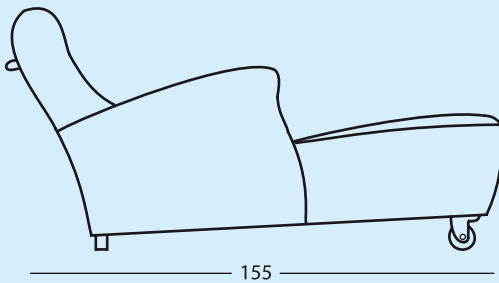
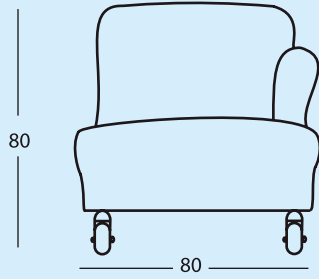
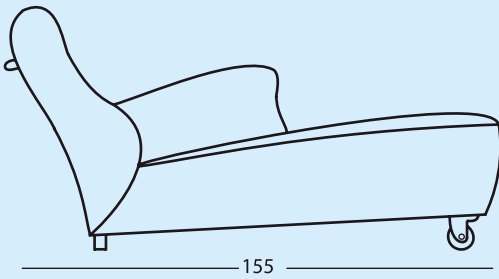



**Giovannetti**

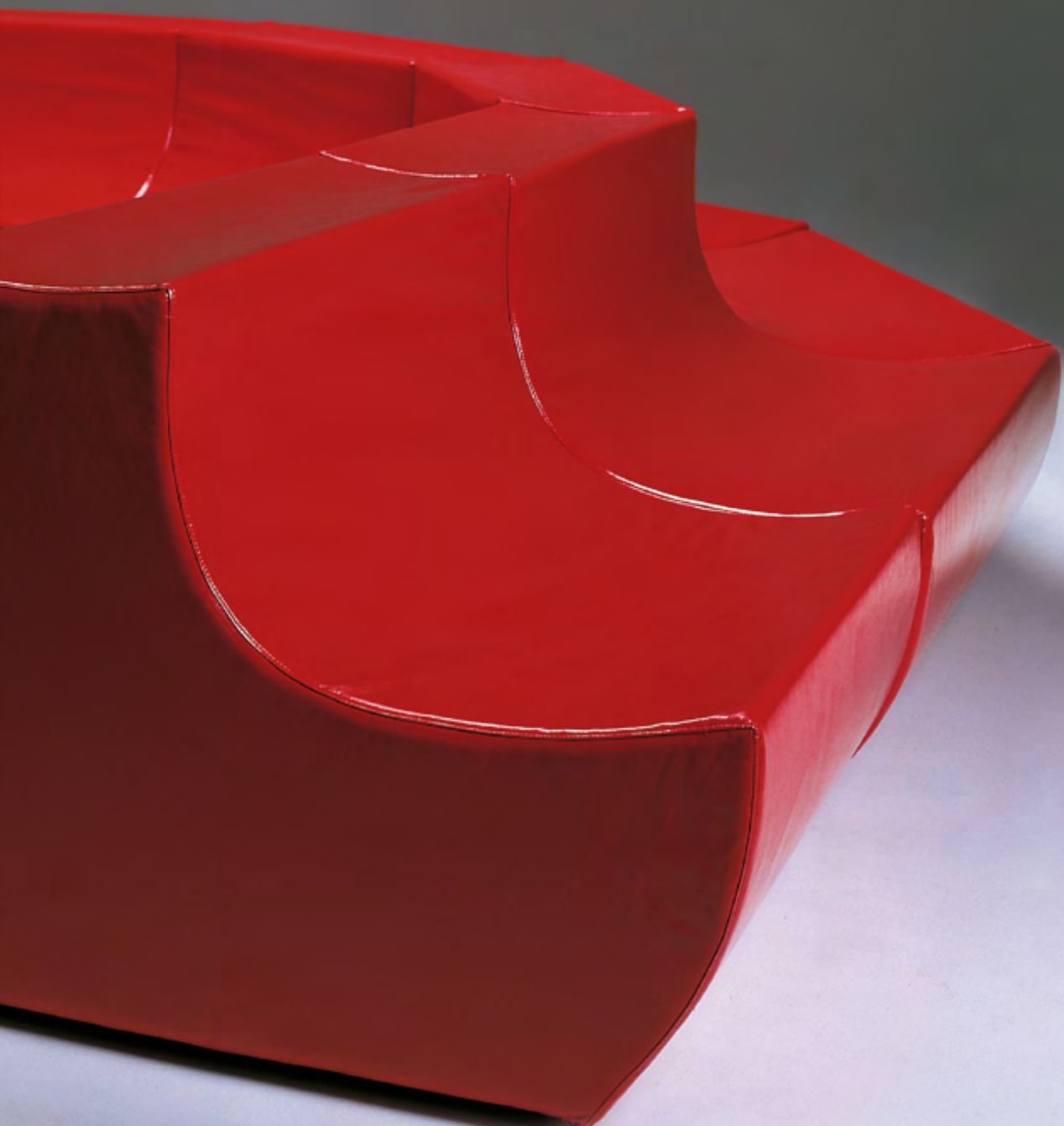

# link 1+2

*Sistema di sedute singole o doppie, che permettono di soddisfare la maggior parte delle esigenze d'arredo, per formare sedute rettilinee, curve e circolari.*

*An ingenious seating system that can be mixed and matched in various formations, satisfying all kinds of furnishing needs.*

Project: N. Delfinetti A. Scarpitta



**Giovanetti**



# link 1

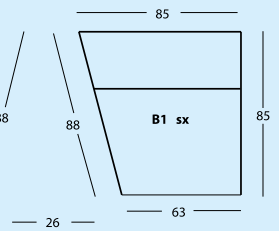
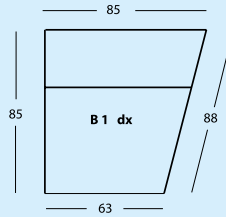
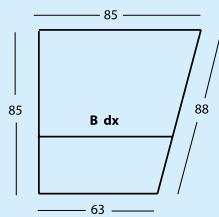
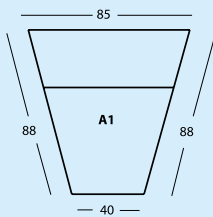
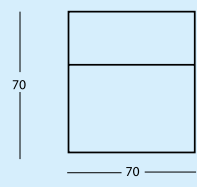
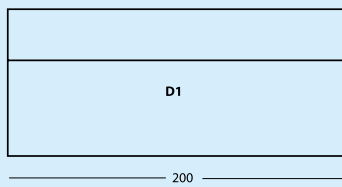
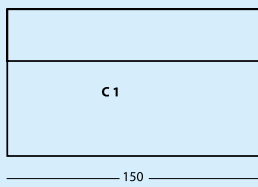
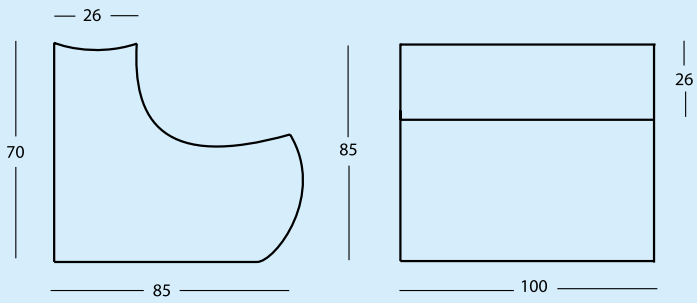



**Giovannetti**

# link 2

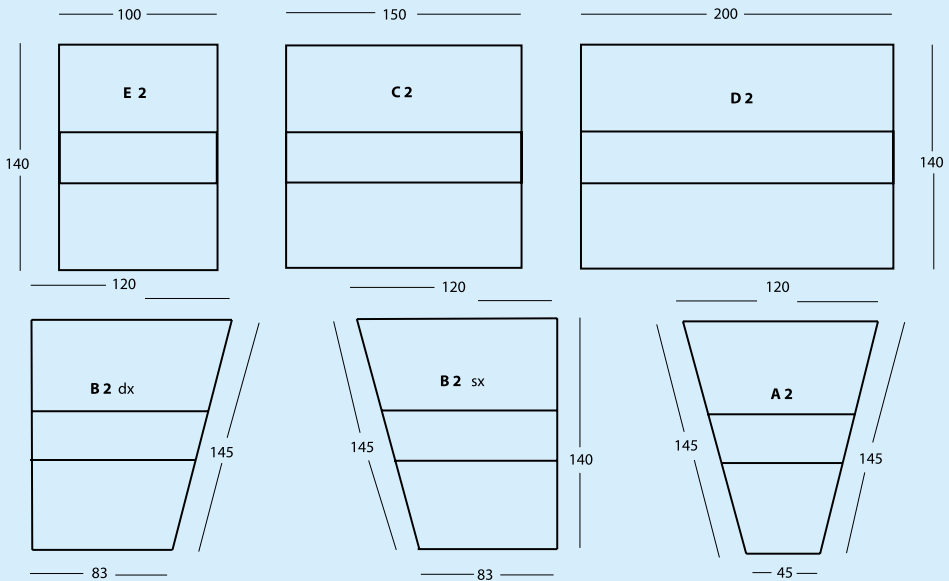
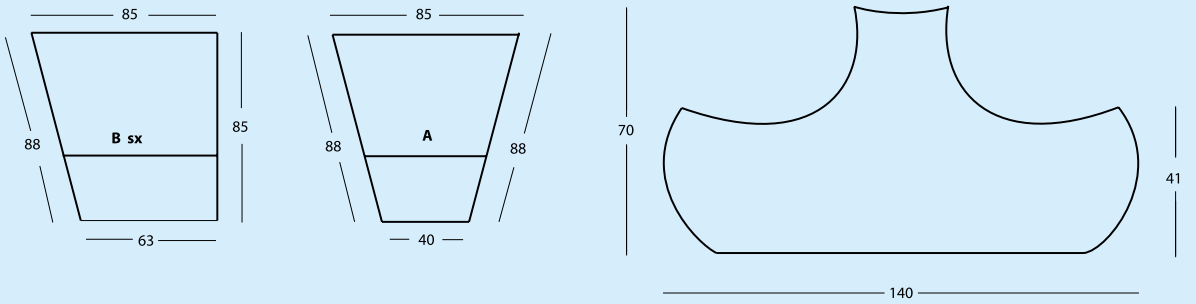

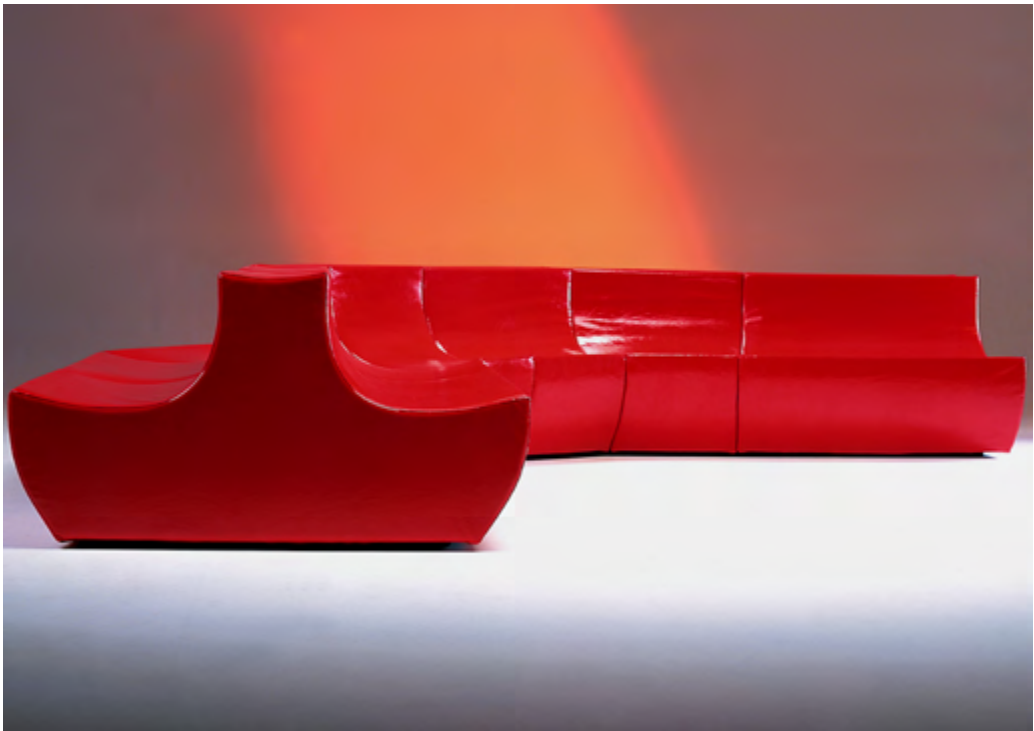

**Giovanetti**





# friendlight

Programma di sedute componibili e singole con profondità variate. Un luogo dove incontrarsi, parlare, riposarsi... Linee essenziali e stile sobrio, arricchiti da morbidi cuscini e da una trapunta estraibile sulla seduta.

*A selection seating system of varying depths that can be combined or used as single pieces. A place for meetings, chats, rest... Essential lines and a sober style, enriched by soft cushions with a removable quilt.*

N. Delfinetti A. Scarpitta, 2001







# friendlight

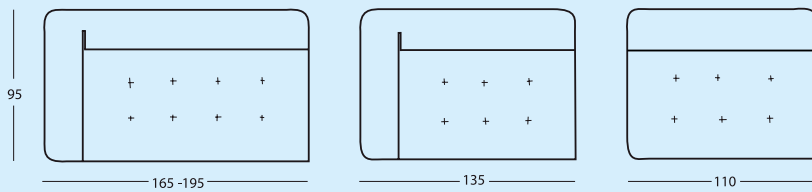
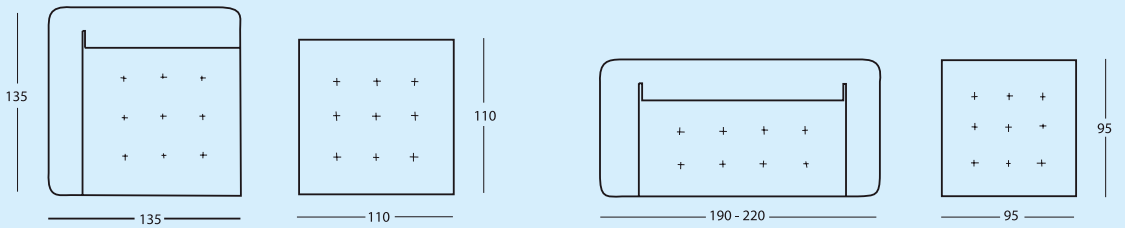
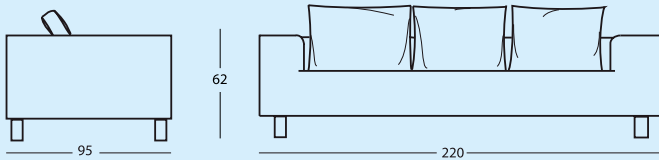
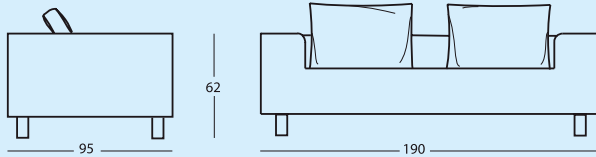



**Giovanetti**





# alice

*Linee morbide e angoli smussati per una poltroncina che è un sottile ed accogliente segno grafico, che si adatta con elegante e semplice naturalezza a qualsiasi ambiente. Ha una struttura essenziale in tondino di acciaio, seduta imbottita e rivestimento sfoderabile.*

*Soft lines and round corners for a chair that represents a thin and comfortable design, suitable to any environment in a simple and elegant way. It has a minimalist steel rod structure and a padded seat, with removable cover.*

project: Space Time, 2005



# alice

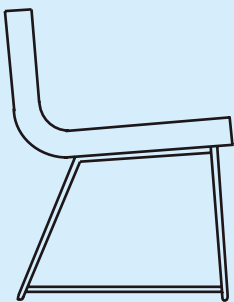

54

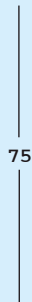

75

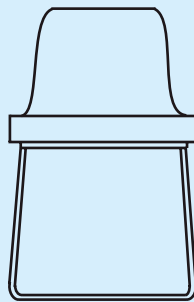

46

46

**Giovannetti**







# nausicaa

Poltrona elegante, da conversazione. Il particolare della spalliera a forma di luna è in faggio per una maggiore comodità.

*An elegant armchair suitable for conversation, with detailing finished in high quality wood and brass.*

Project: Marco Matteini, 1991







# nausicaa

Project: Marco Matteini, 1991

Poltrona elegante, da conversazione. Il particolare della spalliera a forma di luna è in faggio per una maggiore comodità.

*An elegant armchair suitable for conversation, with detailing finished in high quality wood and brass.*

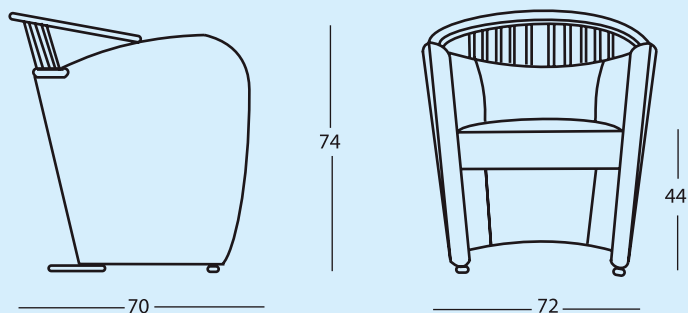



**Giovanetti**





# multilove

*Multilove...un insieme di elementi dal volume semplice, scultoreo, quasi astratto che, combinati, creano un gruppo conversazione dalla forte personalità. Un gioco di composizioni per creare architetture morbide, dinamiche, sensuali... Un luogo in cui incontrarsi e creare il proprio ambiente domestico o pubblico.*

*Multilove ... a range of simple, sculptural, almost abstract elements, able to create - once assembled - the overall effect of dynamic and strong personality shapes. A composition game creating soft, dynamic, sensual architecture.... A place where meeting and creating an individual home or public environment.*

project: Space Time, 2006



# multilove

Struttura in legno. Imbottitura in poliuretano indeformabile a doppia densità rivestita con fibra acrilica e tessuto protettivo. Cuscini volanti in piuma e fiocco di poliestere. Piedi in PVC.

Wooden frame. Double density shape-retaining polyurethane foam, covered with acrylic fibre and protective lining. Cushions padded with feathers and polyester-flakes. Feet in PVC.

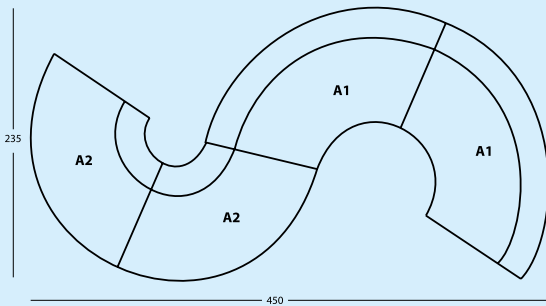

**07 - A2+A2+A1+A1**

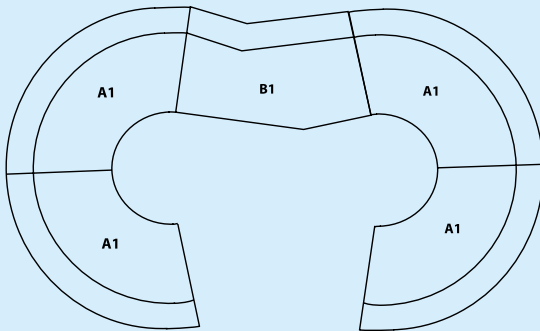

**08 - A1+A1+B1+A1+A1**

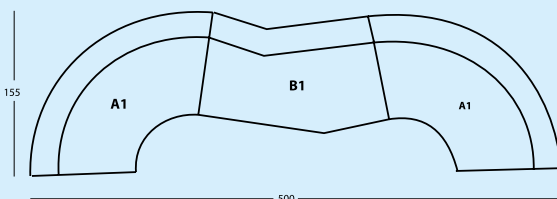

**08 - A1+B1+A1**



**Giovannetti**



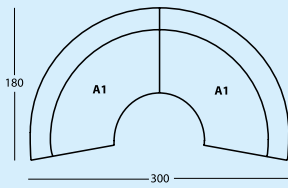
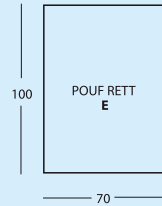
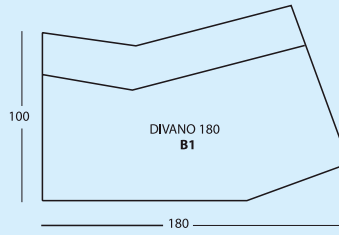
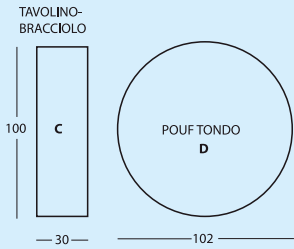
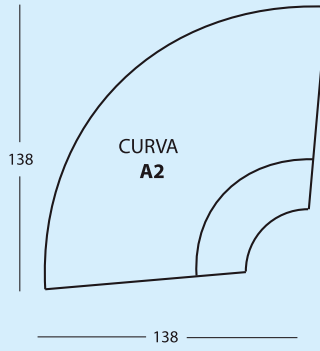
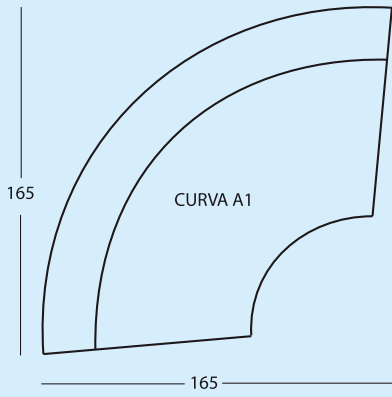

01 - A1+A1

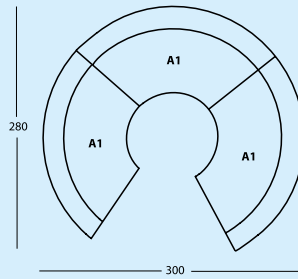

02 - A1+A1+A1

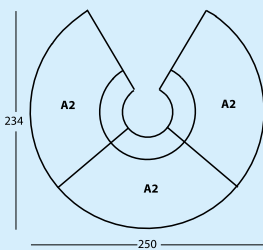

03 - A2+A2+A2

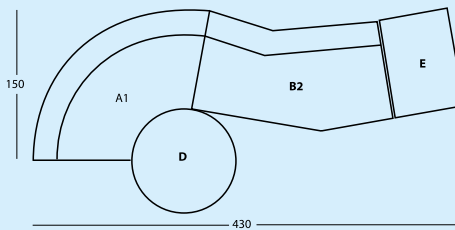

04 - A1+B2+E+D

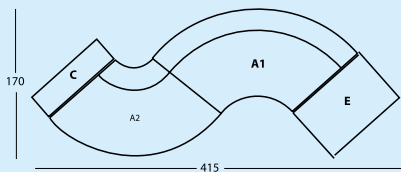

05 - C+A2+A1+E

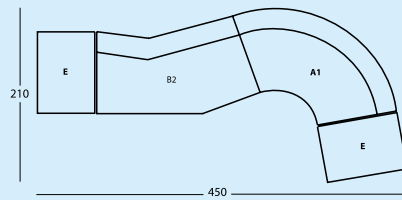

06 - E+B2+A1+E





**Giovannetti**

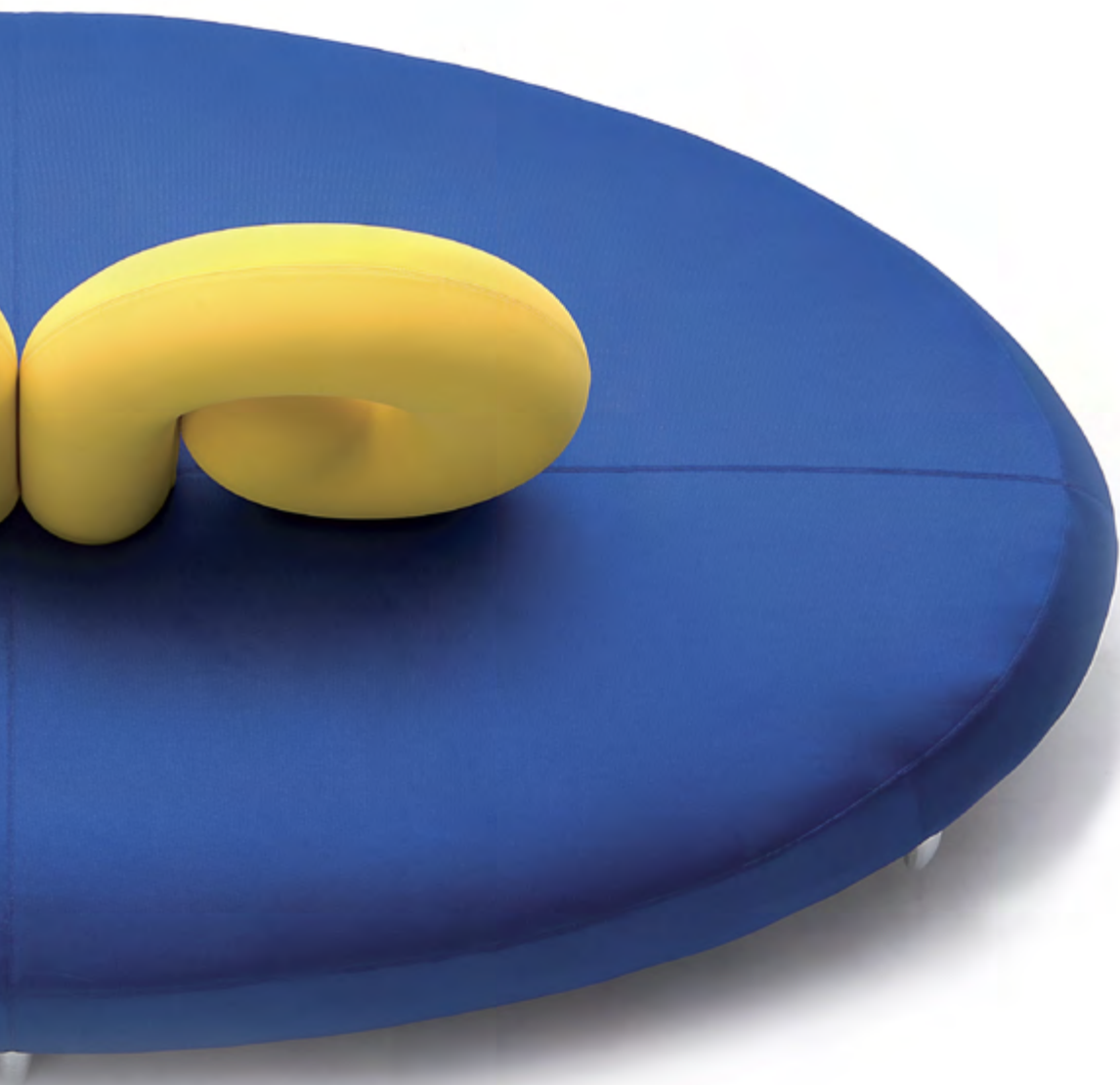

**Giovannetti**

# aries

*L'unione tra i principi creativi come Terra e Cielo, Femminile e Maschile, è riscontrabile nel rapporto estetico tra la seduta del divano, che con la sua forma ellittica, armoniosa ed allo stesso tempo avvolgente, rappresenta la grazia e la leggerezza femminile, e lo schienale, immagine virile, dinamica, nelle sue linee di forza, che ritroviamo nel principio maschile.*

*Joining of creative principles such as Earth and Sky, Female and Male, is verifiable in the relation between the sofa seat; in its elliptical, harmonious, wrapping feature we find lightness and feminine grace; and the back, representing virility, dynamism and the force of the masculine principle.*

Project : Pietro Cavallo, 2007

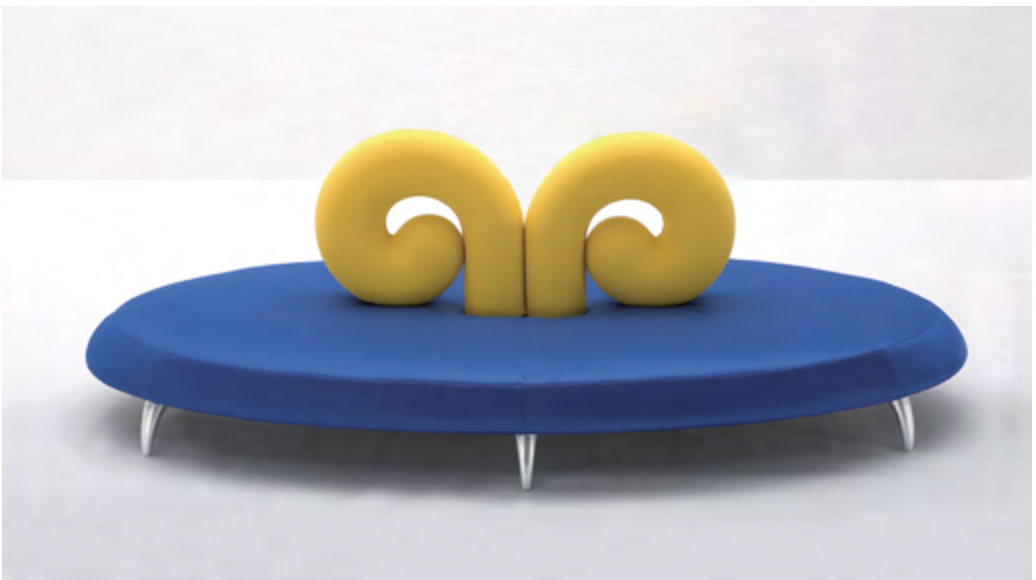

**Giovanetti**

# aries

Seduta ellittica: Struttura in multistrati di faggio, imbottitura in poliuretano ad alta densità, rivestito con tessuto protettivo. Schienale: struttura in acciaio

Elliptical seat: wooden frame, high density polyurethane foam covered with protective lining. Back: Steel frame

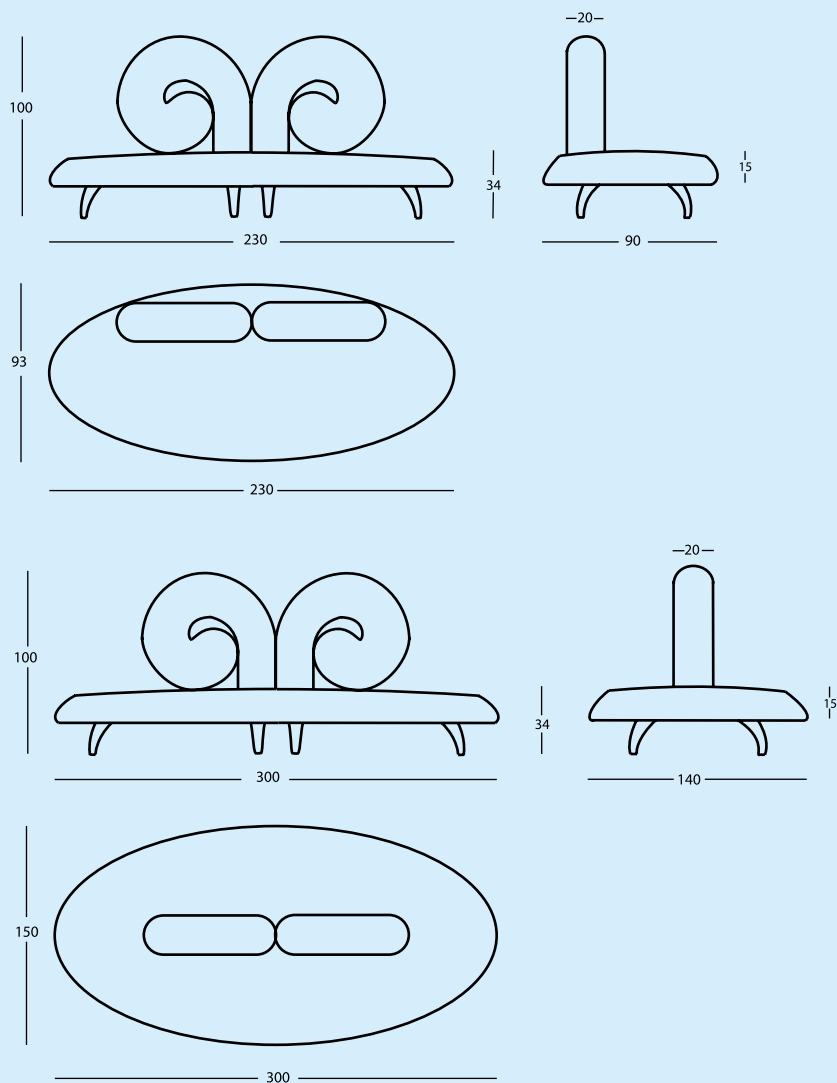



**Giovanetti**





# papessa



**Giovannetti**

# papessa

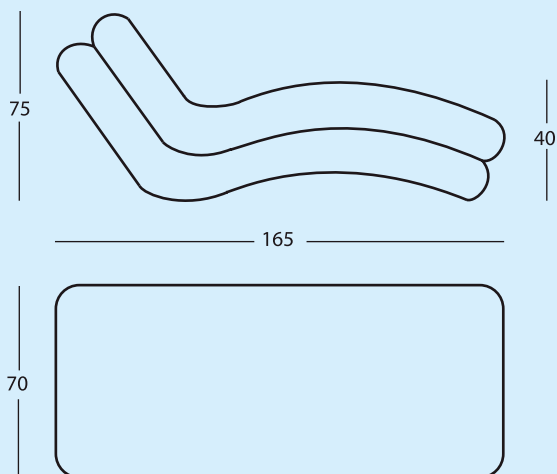



**Giovannetti**





# le zucche

*Pouf seduta, romantica, colorata.  
Elaborazione di un blocco di poliuretano  
indeformabile  
con tessuto modellato  
ed accoppiato con forti  
spessori di fibra ovattata.  
Appoggia a terra su forma rotonda  
di multistrati supportata da una serie di  
distanziali in P.V.C.*

Project: 2017



# le zucche

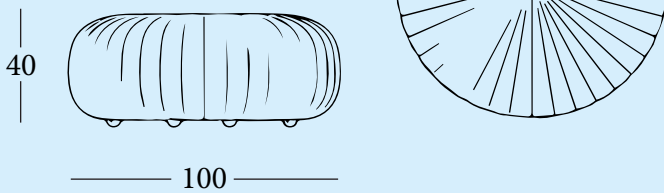



**Giovanetti**



# teso

*Il tavolo può essere usato come tavolo studio oppure come tavolo da pranzo. I cavi tesi d'acciaio danno una sicura stabilità e lo rendono sobrio e armonioso, mettendo in evidenza la sua forma. Struttura in massello di faggio, tinto nei colori desiderati. Cristallo di mm.15 si può fornire a richiesta temperato e con certificato shock-test.*

*The table can be used as office table or dining table. The taut steel cables give a safe stability, making it sober and harmonious, highlighting its shape. Solid beech structure, dyed in the desired colors. 15 mm crystal can be provided upon request with tempered and certified shock-test.*

Project: Superstudio 1975





teso

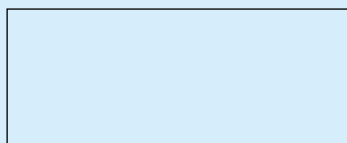
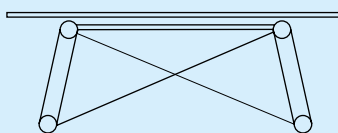
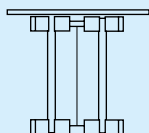



**Giovanetti**



# jolly

*Serie di tavolini da appoggio in tre forme.*

*Si distinguono in:*

*Jolly round - Jolly square - Jolly mix*

*Series of small tables, available in  
three different features:*

*Jolly round - Jolly square - Jolly mix*

Enrico Buscemi PiergiorgioLeone, 2005



# jolly

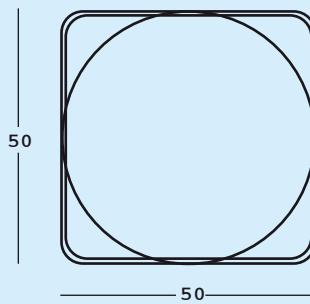
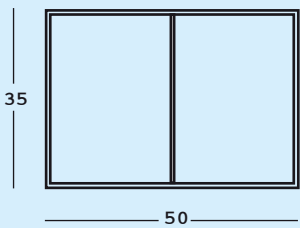
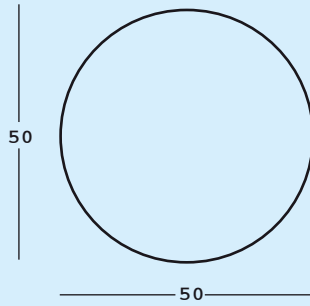
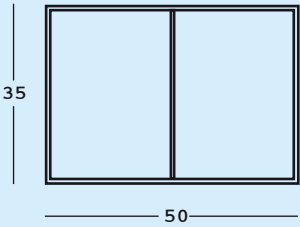
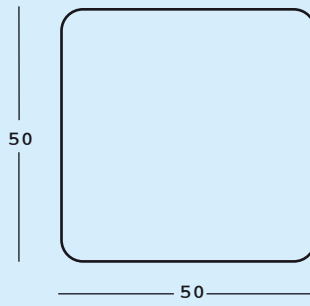
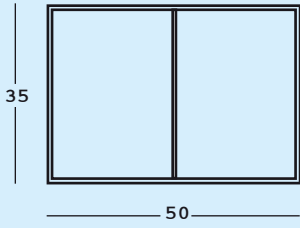

**Giovanetti**





**Giovanetti**



**Giovannetti**

# ring

*Un'idea nata come omaggio all'opera di Henry Moore/ grande maestro inglese che ha rivoluzionato il mondo dell'arte moderna. Il tavolo e lo sgabello devono la loro leggerezza stilistica ai grandi fori che diventano comode nicchie per borse, riviste e piccoli oggetti. Regolabili in altezza con pistone a gas con Ring l'arte diventa funzione.*

*An idea born as a homage to Henry Moore the great english master, who changed the world of Modern Art. Table and stool owe their lightness to the big holes, that become a suitable place for bags, magazines and small objects. A gas piston allows to set highness according to users needs. Ring makes art become function.*

project: Giancarlo Zema, 2006



**Giovannetti**

# ring



4011 1028

i colori suggeriti nel programma Ring sono stati selezionati nella gamma RAL



4010 5002

for the Ring elements we have selected the following combinations among the RAL colour range



1028 4010



9010

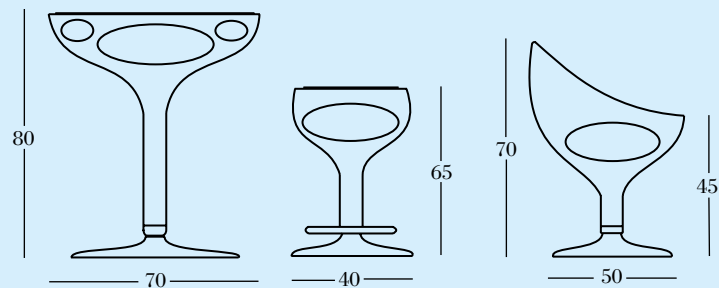
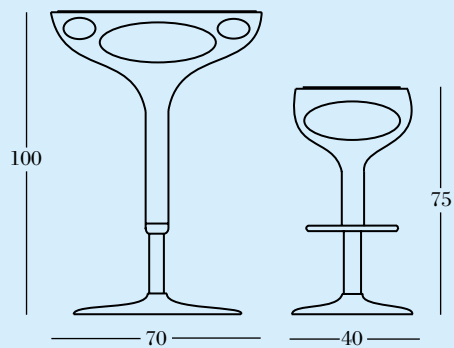



**Giovannetti**







# saarinen



4011



1028



4010



5002

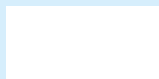

9010

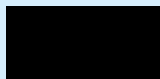

9011

i colori suggeriti nel programma  
Ring sono stati selezionati nella  
gamma RAL

for the Ring elements  
we have selected  
the following combinations  
among the RAL colour range

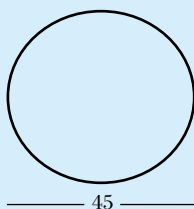
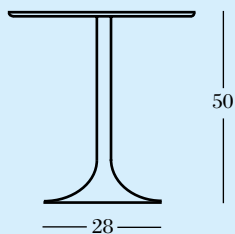



# saarinen

*Struttura in fusione d'alluminio levigata e verniciata. Piano in MDF ad alta densità.  
Nei colori panna, fucsia e giallo.*

*Structure in aluminium fusion. Table in high density MDF. Colours: creme, fuchsia and yellow.*

project: Atelier Associati, 2007







# moss

*Il muschio con la sua trama soffice e colorata che si adatta morbidamente alle forme della natura, ha sedotto la matita dell'architetto Giancarlo Zema, che ha creato per la Giovannetti una collezione di sedute e tavoli bassi dai colori freschi e dalle superfici avvolgenti. Ideale per arredare gli spazi outdoor e indoor più innovativi e di tendenza.*

*The moss with its soft and colourfull texture that fits smoothly to the forms of nature, has seduced the pencil of the architect Giancarlo Zema, who has created for Giovannetti a collection of seats and low tables in fresh colours and enveloping surfaces. Ideal for decorating the most innovative and trendy outdoor and indoor spaces.*

Project: Giancarlo Zema, 2018



**Giovannetti**

# MOSS

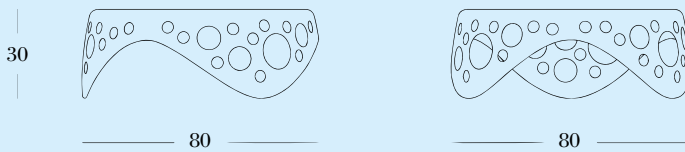
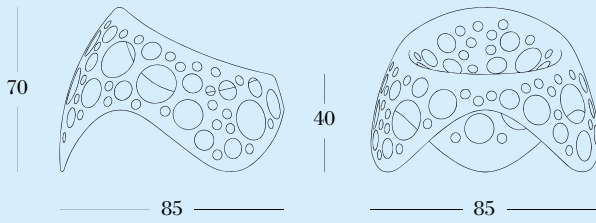
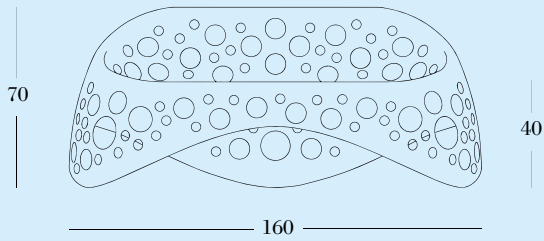













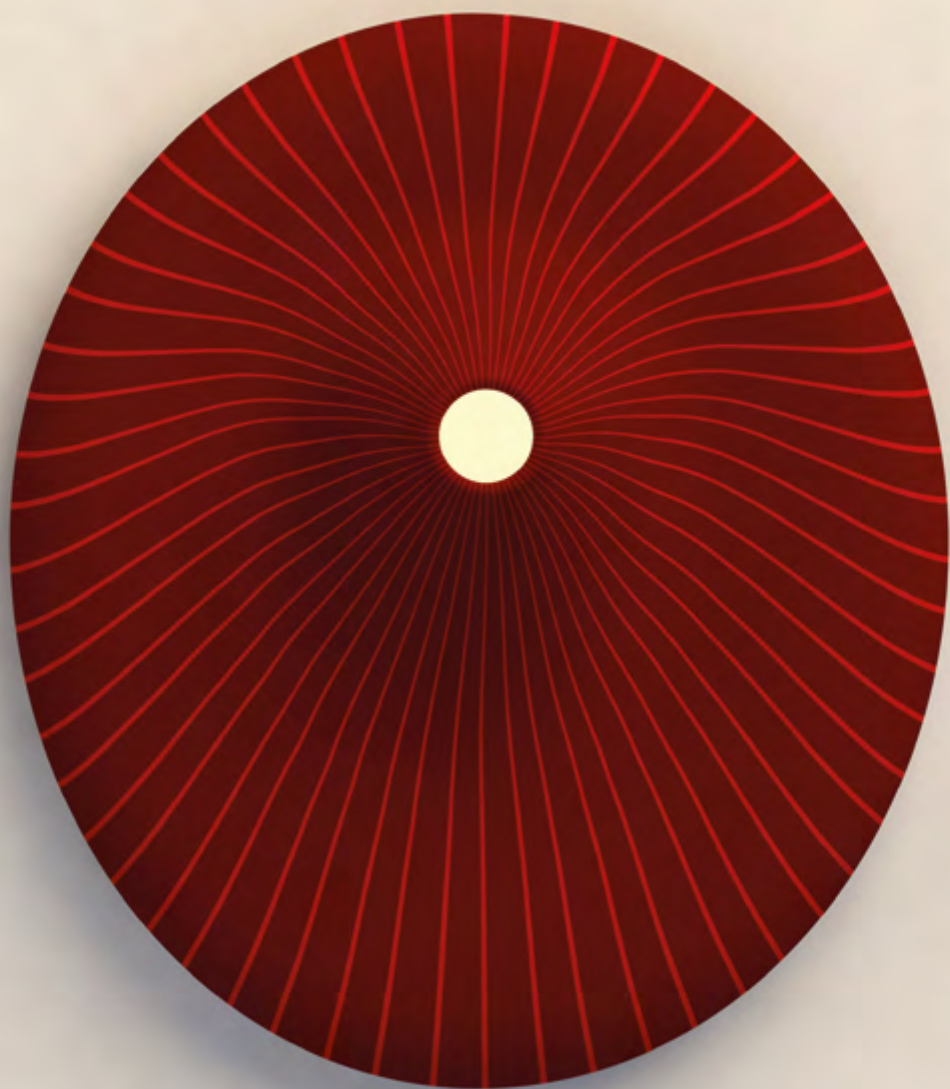

# o vulcano

*Il divano centrale O Vulcano con il suo dolce profilo ci invita a scegliere la giusta postura, sdraiato come in una chaise-longue oppure seduto come in un divano normale. Una luce fuoriesce dalla sua bocca a ricordarci la sua funzione, ma non mete paura anzi, rilassa.*

*The central sofa O Vulcano with its sweet profile invites us to choose the right posture, lying down like in a chaise-longue or sitting like a normal sofa. A light comes out of his mouth to remind us of his function, but do not fear, on the contrary, relax.*

Project: Roberto Semprini, 2018



**Giovanetti**

# o vulcano

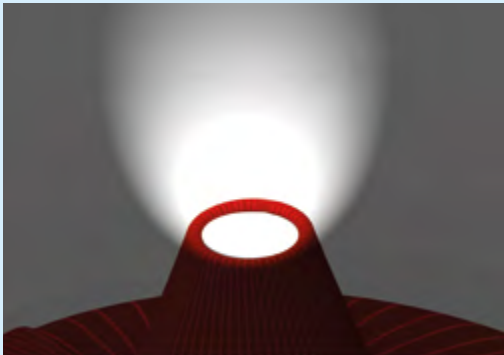

dalla bocca di vulcano fuoriesce un fascio di luce

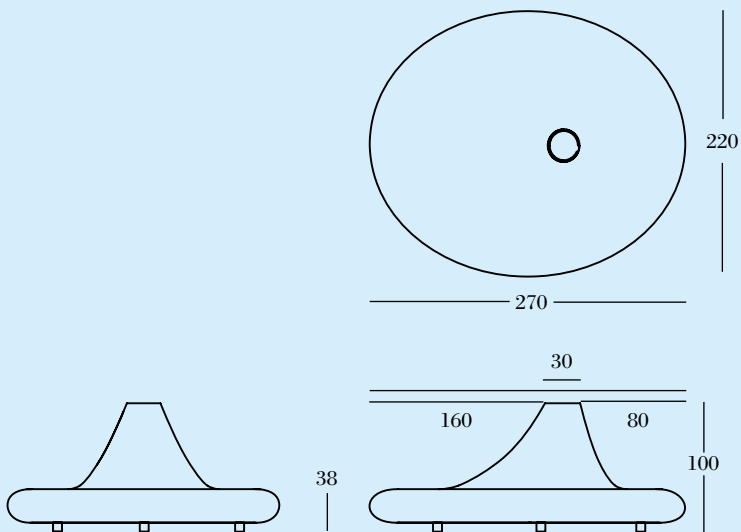

**Giovanetti**



**Giovannetti**





**Giovannetti**





**Giovannetti**

**Giovannetti**

**Giovannetti**

**Giovannetti**